

PRODUCT DESCRIPTION

Marine Air introduces the new "AT" line of chilled water air handlers. These are draw-through (ducted) units that replace the Flex-Duct and Draw-Through models, and offer many improvements over the existing units.

Significant improvements include: sloped "Positive-Flow" drain pan which reduces standing water, remote electrical box for easier wiring, improved coil design for better cooling and dehumidifying performance, coil is off-set from drain pan edge to ensure all condensation is caught in the pan, redesigned piping so the bypass valve is clear of dripping condensation, pressure test ports for troubleshooting, and the new 24,000 BTU/Hr unit uses a high-efficiency, internal-motor blower for quieter operation.

On units with auxiliary (electric) heat, the new heater design allows removal from the top or side for access or servicing.

FEATURES

- Compact design, with large coil shroud volume for optimum performance
- High-efficiency PSC internal-motor blower is standard ("HV" models)
- Coils are 3 or 4 rows for improved cooling and dehumidification
- Sloped, Positive-Flow drain pan with anti-slosh, antifungal foam
- Integrated chassis with vibration isolation mounting feet
- Exposed sheet metal is insulated to prevent secondary condensation
- Remote air bleeder on 6ft (1.8m) of flexible tubing with ball valve
- User friendly, remote electrical junction box with 6ft (1.9m) wire harness
- 24K unit with high-efficiency internal-motor blower
- Water pressure test ports for troubleshooting
- Allowance for connecting variable fan speed drives
- Rotatable blowers
- Washable air filter included. Micro-Particle Anti-Allergenic air filters available.
- ISTA certified packaging



AT18HV model shown

Options for "HV" and "F" models

- Electric heat with two-stage electric heat overload (no thermo-fuse), heater assembly accessible from top or side

Options for "HV" models

- Modulating flow control to ensure uniform water distribution
- Corrosion resistant coated evaporator coil
- Pre-rotated blowers
- Right-hand water connections
- 3ph electric heat available

Options for "F" models

- "F" models have low-cost, shaded-pole, external-motor blowers
- No-Valve units available in "F" models only

SPECIFICATIONS

Model ^{(1) (2)}	AT4F		AT6		AT9		AT12		AT18		AT24HV		AT36HV	
Capacity (BTU/Hr)/(Kcal/Hr)	4,000/1,008		6,000/1,512		9,000/2,268		12,000/3,024		18,000/4,536		24,000/6,048		36,000/9,072	
Voltage @ 50-60Hz/1Ph	115	230	115	230	115	230	115	230	115	230	115	230	115	230
Amperage (FLA) Cool "HV"	n/a		1.2	0.6	1.4	0.7	1.4	0.7	2.2	1.0	2.2	1.0	1.6	
Amperage (FLA) Cool "F"	0.9	0.5	2.0	0.9	2.9	1.6	2.9	1.6	3.3	1.8	n/a		n/a	
Optional Electric Heaters ⁽³⁾	n/a		1.0		1.5		2.0		3.0		3.0		4.0	
Element Size (kW)	n/a		1.0		1.5		2.0		3.0		3.0		4.0	
Rating (BTU/Hr)/(Kcal/Hr)	n/a		3,412/860		5,118/1,290		6,824/1,720		10,236/2,579		10,236/2,579		13,648/3,439	
Amperage (FLA) Heat "HV"	n/a		9.9	4.9	14.4	7.2	18.8	9.4	28.3	14.0	28.3	14.0	19.0	
Amperage (FLA) Heat "F"	n/a		10.7	5.2	15.9	8.1	20.3	10.3	29.4	14.8	n/a		n/a	
Max. Fuse/Min. Circuit Ampacity	n/a		5/3	5/1	5/2	5/1	5/2	5/1	5/3	5/2	5/3	5/2	5/3	
Without Electric Heat "HV"	n/a		5/3	5/2	5/4	5/2	5/4	5/2	5/5	5/3	n/a		n/a	
Without Electric Heat "F"	5/2	5/1	5/3	5/2	5/4	5/2	5/4	5/2	5/5	5/3	n/a		n/a	
With Electric Heat Option	n/a		10/9	5/5	15/14	10/7	20/18	10/9	30/27	15/14	30/27	15/14	25/20	
GPM/(liters/min.)	1.0/3.8		1.5/5.7		2.3/8.5		3.0/11.4		4.5/17.0		6.0/22.7		9.0/34.1	
	50	60	50	60	50	60	50	60	50	60	50	60	50	60
CFM/(M ³ /Hr.) NOMINAL "HV"	n/a		196	240	218	285	291	381	381	492	395	506	711	773
External SP (in. H ₂ O/eq. Ft.) "HV"	n/a		.30/25	.30/17	.30/44	.30/26	.30/25	.30/15	.30/41	.30/25	.30/62	.30/37	.30/19	.30/16
CFM/(M ³ /Hr.) NOMINAL "F"	81	112	na	143	na	307	na	325	na	386	n/a		n/a	
External SP (in. H ₂ O/eq. Ft.) "F"	.30/45	.30/27	na	.30/48	na	.30/23	na	.30/20	na	.30/41	n/a		n/a	
Dimensions (in/mm) ⁽⁴⁾														
Height Excluding Blower	10.72/272		10.20/259		11.90/302		12.05/306		14.96/380		16.61/422		19.50/495	
Height to Blower "HV"	n/a		13.63/346		13.25/337		13.88/353		16.50/419		16.68/424		19.50/495	
Height to Blower "F"	9.43/240		12.45/316		13.61/346		13.66/347		15.06/383		n/a		n/a	
Width	14.75/375		15.00/381		16.63/422		18.75/476		20.25/514		22.63/575		26.63/676	
Depth of both "HV" & "F"	6.70/170		12.28/312		12.50/318		12.50/318		12.25/311		15.25/387		18.00/457	
Motor Overhang on model "F"	2.92/74		2.83/72		2.46/62		2.24/57		4.51/115		n/a		n/a	
Supply Air Duct Diameter	4/102		5/127		6/152		6/152		7/178		8/203		8/203	
Remote Mount Electric Box	8.00"/203mm High X 6.13"/156mm Wide X 2.00"/51mm Deep													
Return Air Inlet (sq in/cm)	64/413		70/452		98/632		130/839		200/1,290		240/1,548		360/2,323	
Supply Air Outlet (sq in/cm)	32/206		35/226		49/316		70/452		100/645		140/903		196/1,265	
Water Connections	Drain: 1/2" FPT w/PVC HB. Chilled Water: 1/2" FPT on 4-24, 1" FPT on 36, with brass HB on all.													
Net Weight (lbs/kg) ⁽⁵⁾	14.0/6.4		18.4/8.3		24.0/10.9		24.0/10.9		32.8/14.9		38.0/17.2		60.0/27.2	
Gross Weight (lbs/kg) ⁽⁵⁾	24.0/10.9		28.4/12.9		34.0/15.4		34.0/15.4		36.8/16.7		52.0/23.6		66.0/29.2	

Note: See back of sheet for dimensional drawing and specification notes.

Installation Guidelines for AT Air Handlers

When choosing the proper AT Air Handler model, primary consideration should be given to calculated BTU loads and available power supply.

AT series air handlers are ductable units, designed to be installed low in cabin areas (under berths, lockers, etc.) and ducted to high supply air grills. These units have rotatable blower-motor assemblies, providing flexibility to fit specific space requirements and allowing for proper duct work installations. Combinations of transition boxes may be used to supply air into more than one area from a single unit.

Securely fasten the AT to a solid, level surface, using the mounting hardware provided. Be sure that the blower motor has at least 3" inches of space in front of it to allow for proper air flow. Rotate and secure the blower, if necessary, to its proper position to provide the most direct routing of the ducting to transitions and supply air grills. Route all ducting as smooth and straight as possible. Trim off excess ducting before making final connections. Secure the ducting every 48" (min.) to prevent movement while the vessel is under operation.

The return air inlets must be properly sized and located to allow adequate return airflow to the units. A return air filter is supplied standard with each unit. These filter assemblies should be checked periodically and cleaned when necessary. The return air grille should not be located in such a way as to allow the supply air stream to blow directly into its opening. This will cause "short cycling" of the unit, resulting in poor performance.

The supply air grill(s) must be sized and located to allow for proper air circulation within the cabin area(s). Grill locations close to the ceiling or directed upwards provide for the best air circulation. Under-sized grills and crushed or kinked duct work will result in poor or inadequate performance.

Connect a 5/8" reinforced flexible condensate hose to the drain pan spud furthest aft. Two drains may be teed together, providing there is a minimum drop of 2" from the drain pan to the tee fitting. The drain line must be routed downward to a proper sump or overboard discharge.

Properly secure the drain lines to prevent movement during vessel operation. Check the drains upon completion by pouring two quarts of water into the drain pan. **Note: Condensation drain lines may need to be insulated when located in high heat load areas to prevent line sweating, which could cause water damage.**

CAUTION: Never install your air handler in the bilge or engine room areas. Insure that the selected location is sealed from direct access to bilge and/or engine room vapors. Do not terminate condensate drain line within three (3) feet of any outlet of engine or generator exhaust systems, nor in a compartment housing an engine or generator, nor in a bilge, unless the drain is connected properly to a sealed condensate or shower sump pump.

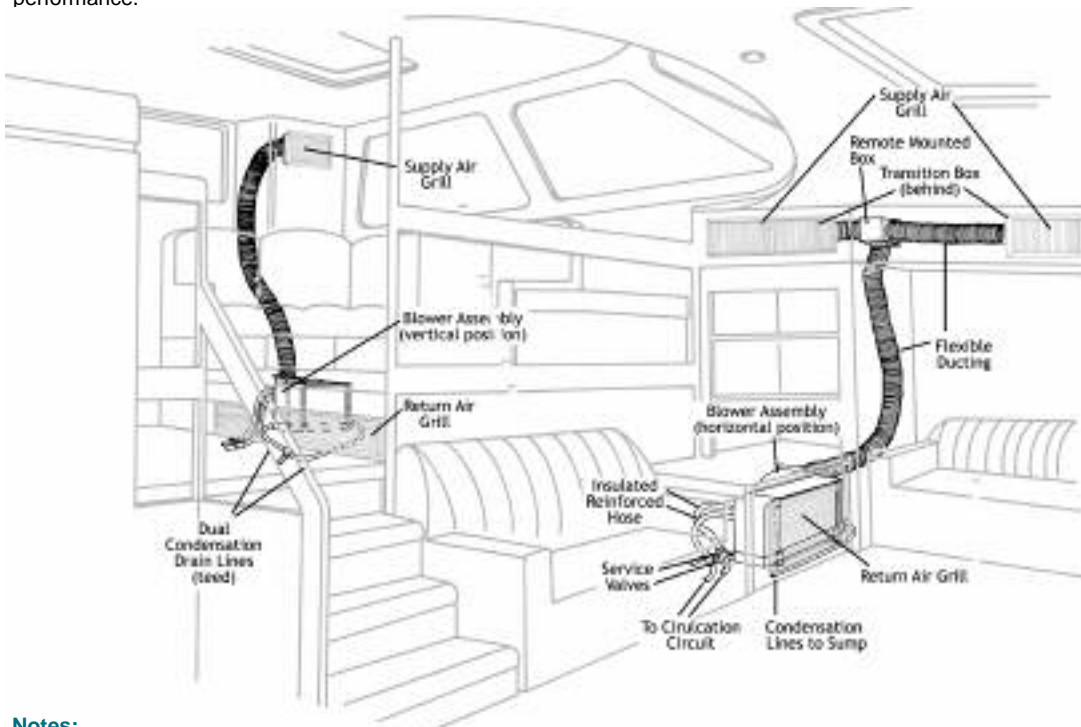

DIMENSIONAL DRAWING

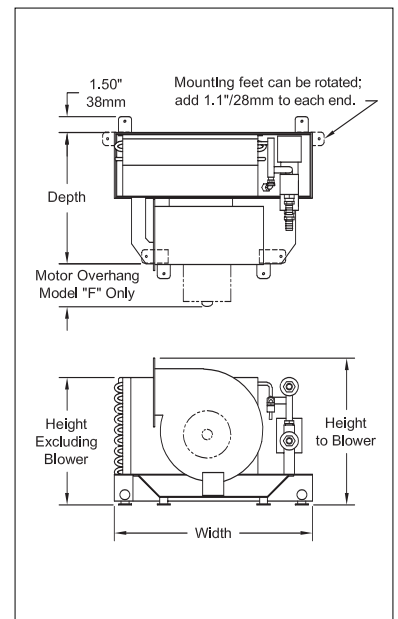

Notes:

- Model numbers shown are for 115V units. Add a "Z" after the "HV" or "F" in the model number to designate 230V (i.e. AT12HVZ). Model number prefixes: -FC = Flow Control; -L# or -R# = Valve & Blower Rotation (see dwg H3050002); -#KW = Electric Heat Option.
- 50 HZ is not recommended for "F" models. AT4F may be run at 50 HZ. "HV" models use a high efficiency PSC internal-motor blower, "F" models use a shaded pole blower motor.
- Auxiliary heating elements are optional, and must be ordered with unit. Add "1KW, 1.5KW, etc." to the model number.
- Rotatable feet affect the final dimensions. Front feet add 1.5" to the front, or 1.1" to both sides. Rear feet do not add to the width or depth when rotated to the side.
- Weights listed are for standard "HV" units. For weights of units with the electric heater option, add heater elements weights to unit weight. 1.0kW & 1.5kW = 1.5 lbs/0.7 kg; 2.0kW & 3.0kW = 3.0 lbs/1.4 kg. Dimensional weights may apply to shipping charges; contact your sales-admin representative.

In the interest of product improvement, specifications and design as outlined herein are subject to change without prior notice.

Dometic Environmental Corporation

2000 N. Andrews Ave. Ext. • Pompano Beach, FL 33069-1497 USA
Phone: 954-973-2477 • Facsimile: 954-979-4414

P.O. Box 15299 • Richmond, VA 23227-0699 USA
Phone: 804-746-1313 • Facsimile: 804-746-7248

For Sales and Service calls Within Europe and the Middle East, please contact: +44 (0) 870 330 6101

Email: sales@marineair.com • Website: www.marineair.com

Sold and Serviced by: