

PRODUCT DESCRIPTION

Marine Air introduces the new “AT-MU” line of chilled water fresh air makeup air handlers. These are draw-through (ducted) units that replace the current models, and offer many improvements over the existing units.

AT-MU air handlers are designed for use in fresh air make-up (FAMU) systems where outside air is drawn in by the air handler, cooled, dehumidified, and reheated to room temperature, and then ducted to various areas in the vessel. The unit consists of a water coil, valve, electric heater, and a blower mounted on a condensate pan/chassis with rubber isolation mounting feet.

A specially designed water coil cools and dehumidifies the outside air in one pass, and is coated, along with the blower and sheet metal, to prevent corrosion. A motorized 3-way bypass valve controls the flow of circulated water through the coil. The high static pressure blower has a high-efficiency internal motor, and can be rotated as required for installation. An electric heater, with redundant over-temperature protections, is included to reheat the cooled air up to a comfortable temperature.

The sloped “Positive-Flow” condensate pan reduces standing water, and is lined with anti-fungal, anti-slosh foam. An optional modulating loop-water flow control regulates the water through the unit to ensure proper water distribution to all air handlers.

FEATURES

- Compact design, with large coil shroud volume for optimum performance
- High-efficiency PSC internal-motor blower is standard
- Coils are 3 or 4 rows for improved cooling and dehumidification
- Sloped, Positive-Flow drain pan with anti-slosh, antifungal foam
- Integrated chassis with vibration isolation mounting feet
- Exposed sheet metal is insulated to prevent secondary condensation
- Remote air bleeder on 6ft (1.8m) of flexible tubing with ball valve
- Large, remote electrical junction box with 6ft (1.9m) wire harness
- Corrosion resistant coated evaporator coil, blower, and sheet metal
- Water pressure test ports for troubleshooting
- Allowance for connecting variable fan speed drive
- Rotatable blowers
- Washable air filter included
- ISTA Level IIIA certified packaging

Control Box

- “SCR” fired electric heaters pulse to provide consistent supply air temperature
- Two heater overloads, one automatic, one manual, provide maximum protection
- Remote mountable electric box offers installation flexibility



ATMU 36 and ATMU 24 models shown

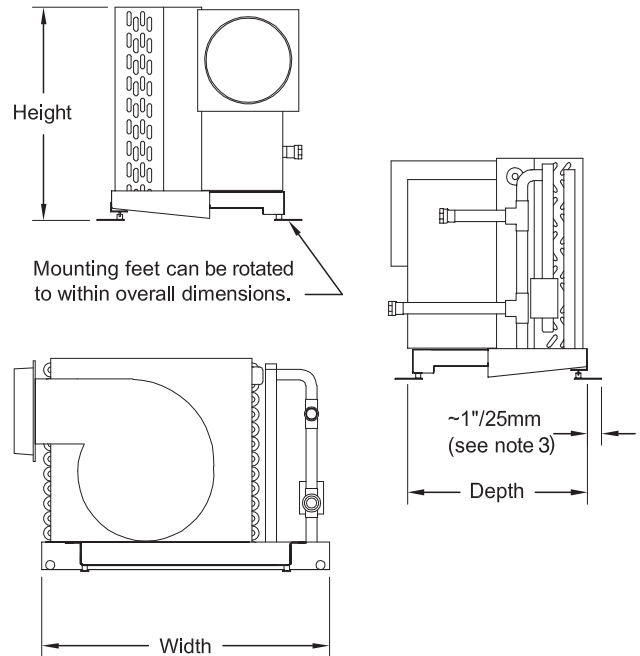

Options

- Modulating flow control to ensure uniform water distribution
- Pre-rotated blowers
- Right-hand water connections
- 3ph electric heat available
- Designed specifically for either 208VAC or 230VAC

TECHNICAL SPECIFICATIONS

Model ⁽¹⁾	AT18HVZ-1.5KW-MU	AT24HVZ-2KW-MU	AT36HVZ-4KW-MU
Capacity (BTU/Hr)/(Kcal/Hr)	17,000/4284	27,000/6804	53,000/13,356
Voltage @ 50-60Hz/1Ph ⁽²⁾	230	230	230
Amperage (FLA)	7.4	9.5	19.1
Max. Fuse/Min. Circuit Ampacity	10/8	10/10	20/20
Electric Heaters			
Element Size (kW)	1.5	2.0	4.0
GPM/(liters/min.)	4.5/17.0	6.0/22.7	9.0/34.1
CFM/(M ³ /HR.) NOMINAL	174/296	276/469	550/935
External SP (in. H ₂ O/eq. Pa)	0.72/180	0.36/90	0.75/190
Dimensions (in/mm) ⁽³⁾			
Height	15.0/380	16.6/422	19.5/495
Width	20.3/514	22.6/575	26.6/676
Depth	12.3/311	15.3/387	18/457
Supply Air Duct Diameter	5/125	6/150	8/200
Return Air Inlet (sq in/cm)	100/645	140/900	220/1400
Loop Water Connections	1/2" FTP with 5/8" brass HB		1" FTP with 1" brass HB
Drain Pan Connections	1/2" FTP with PVC 5/8" brass HB		
Net Weight (lbs/kg)	34/15.5	41/18.6	63/28.6
Gross Weight (lbs/kg)	38/17.3	55/25.0	69/31.4

Notes:

- (1) Electrical and blower data is based on 50Hz performance.
- (2) Verify voltage! Units with SCR-based controls are designed for either 208VAC or 230VAC. Add "208" to the end of the model number for 208VAC units.
- (3) Rotatable feet affect the final dimensions. front feet add 1.5" to the front, or 1.1" to both sides. Rear feet do not add to the width or depth when rotated to the side.

INTERPRETING MODEL NUMBERS

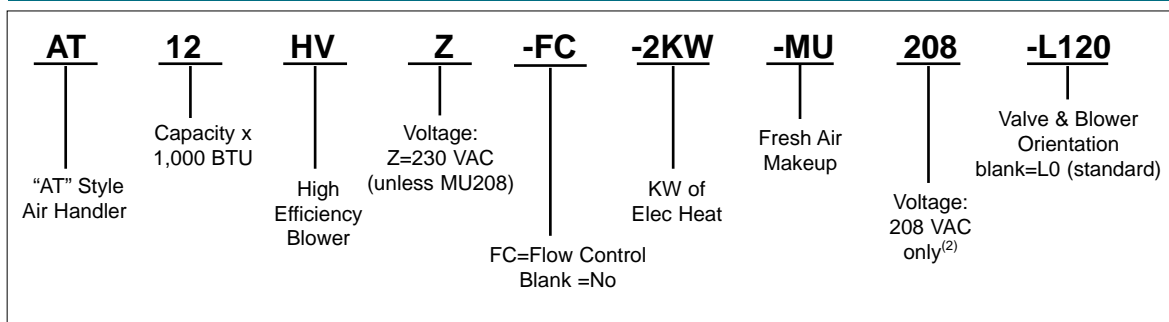

In the interest of product improvement, specifications and design as outlined herein are subject to change without prior notice.

Dometic Environmental Corporation

2000 N. Andrews Ave. Ext. • Pompano Beach, FL 33069-1497 USA
 Phone: 954-973-2477 • Facsimile: 954-979-4414

P.O. Box 15299 • Richmond, VA 23227-0699 USA
 Phone: 804-746-1313 • Facsimile: 804-746-7248

For Sales and Service calls Within Europe and the Middle East, please
 contact: +44 (0) 870 330 6101

Email: sales@marineair.com • Website: www.marineair.com

Sold and Serviced by: